



■ Polycrystalline | GSP6-230/235/240-PR60

PremiumLine

Outstanding features of the PremiumLine by GermanSolar:

- Flash-Data for every panel
- Low chance of mismatching due to extremely low power tolerance of +/-3 %
- Positive classification -0/+4,99 Watt
- Individuell testing and surveying, quality assurance by permanent production control incl. EL-test
- Highest stability thanks to aluminium frame made from a double-walled hollow chamber profile
- Outstanding design thanks to black powder-coated solar panel frame and black backsheet
- Chamfered frame - resulting in improved water drainage and snow run-off
- Good performance by diffused sunlight
- Extremely stable by using 4 mm special-purpose glass
Load capacity: 5400 Pa (Snow and Windload)



Mechanical data

- Dimensions 1.650 x 990 mm
- Thickness 40 mm
- Weight ca. 19 kg
- Laminate/glass 5,8mm / 4 mm ESG extra-white
- impact resistance in accordance with DIN 52337
- black backsheet
- Deformation 1.2° at the module level
- Wind and snow load 5.400 Pa max.

Technical data

The following calculations are based on the electrical data from 60 polycrystalline cells.

Type	GSP6-230-PR60	GSP6-235-PR60	GSP6-240-PR60
Power rating P _{mpp}	230 Wp	235 Wp	240 Wp
Rated current I _{mpp}	7,48 A	7,57 A	7,69 A
Rated voltage V _{mpp}	30,78 V	31,05 V	31,23 V
Short-circuit current	8,04 A	8,15 A	8,24 A
Open-circuit voltage V _{oc}	37,08 V	37,32 V	37,41 V
Module efficiency	14,25 %	14,55 %	14,86 %

- NOCT +47 °C
- Temp.coeff. P -0,44 %/K
- Temp.coeff. I_s +0,075 %/K
- Temp.coeff. V_{oc} -0,343 %/K
- Bypass diodes 3 x in the junction box
- Junction box Certified special box with tension spring clamps
- Connector 1 m plug-in system
- Grenzwerte z
 - Maximum Sytem voltage 1.000 V
 - Rated power tolerance +/-3 %
 - Classification: -0/+4,99 W
 - Operating temp.range -40 bis +85 °C
- Protection class 2

The product manufacturing process for solar module components is based on glass - laminate - technology. In this process, the high quality of the laminate structure is achieved thanks to the laminate and the completely sealed edges. This ensures that the panel will have an extremely long life.

Qualification

This special laminate is certified in accordance with IEC standards 61215 2nd. Ed. and 61730. ID:0000023436 TÜV Rheinland.

Quality

The production facility is TÜV-, MCS-, IEC-, CE-, FSEC-, CEC-, CSA- and ISO 9001:2000-certified, and validated in accordance with EMAS II. Regular individual inspections ensure that the products' electrical, optical and mechanical properties are always of the highest quality.



All electrical values are based on perpendicular solar irradiation at 1.000 W/m² and a temperature of 25 °C (normal conditions with AM = 1,5).

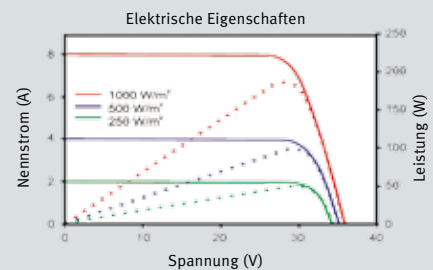
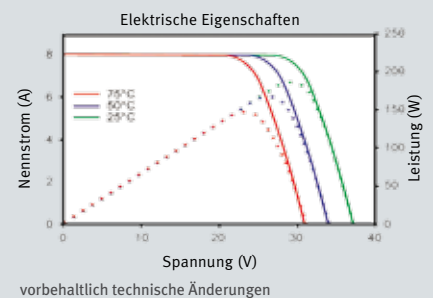
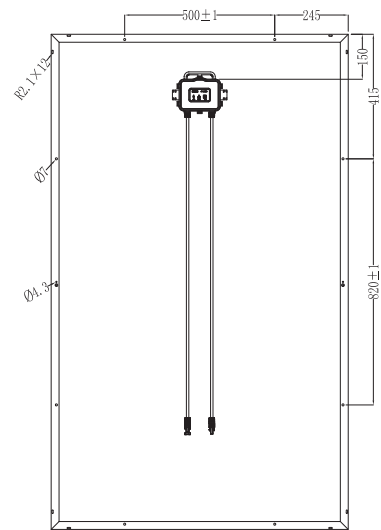
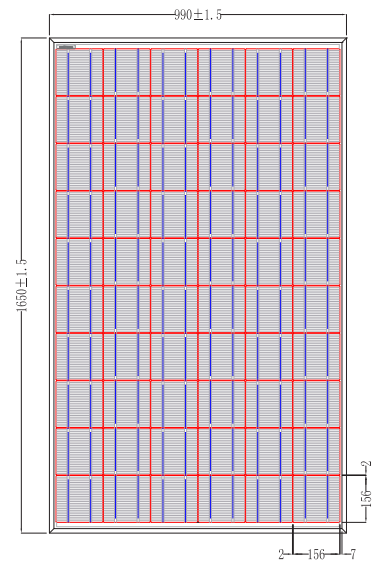

GermanSolar™

GermanSolar AG | Am Seegraben 9-10 | D-03051 Cottbus

fon: +49 (0)1805 - 4949430 * | fax: +49 (0)1805 - 4949431 * | info@germansolar.com | www.germansolar.com

*14 ct./min a. d. dt. Festnetz, max. 42 ct./min. a. d. dt. Mobilfunknetzen, AktivCall GmbH